



## Drying | EVERDRY® FRP

# Cooling with compressed air partial flow: the Heat Regenerating Adsorption Dryer EVERDRY® FRP

Standardised system concepts with a wide range of possible variations: To solve complex tasks in compressed air drying with large volume flow rates very economically!

In-house engineering for individual system solutions!

### The classic concept: Innovatively implemented via the latest system technology

Tried and tested process engineering, paired with the latest control technology, stand for the three variable basic concepts that work ideally worldwide in any climate zone. The standard series is broken down into 23 performance levels from 580 to 20,000 m<sup>3</sup>/h. Higher volume flow rates can also be realised at the customer's request.

In the universal EVERDRY® FRP that can be used worldwide, desorption take place in a counter-flow to the direction of adsorption with heated fan-blown air and cooling by means of a relieved partial flow from the flow of dried compressed air.

#### › Application Oriented Solutions

- › Added value by utilising comprehensive competence
- › Total concept instead of just individual components
- › Informative and user-friendly touch panel control system
- › Easy to maintain

#### › Reliable Process Management

- › Safe function monitoring with sensor technology
- › High-quality high-temperature galvanising
- › Tried and tested, maintenance-friendly components

#### › Energy-optimised Concept

- › Beneficial individual fittings
- › Energy-efficient dew point control system

Model:	FRP	FRA	FRL
Pressure dew point	-40 °C	-40 °C	-40 °C -70 °C option

**FR**

# Heat Regenerating Adsorption Dryer: In-house Engineering for Individual System Solutions

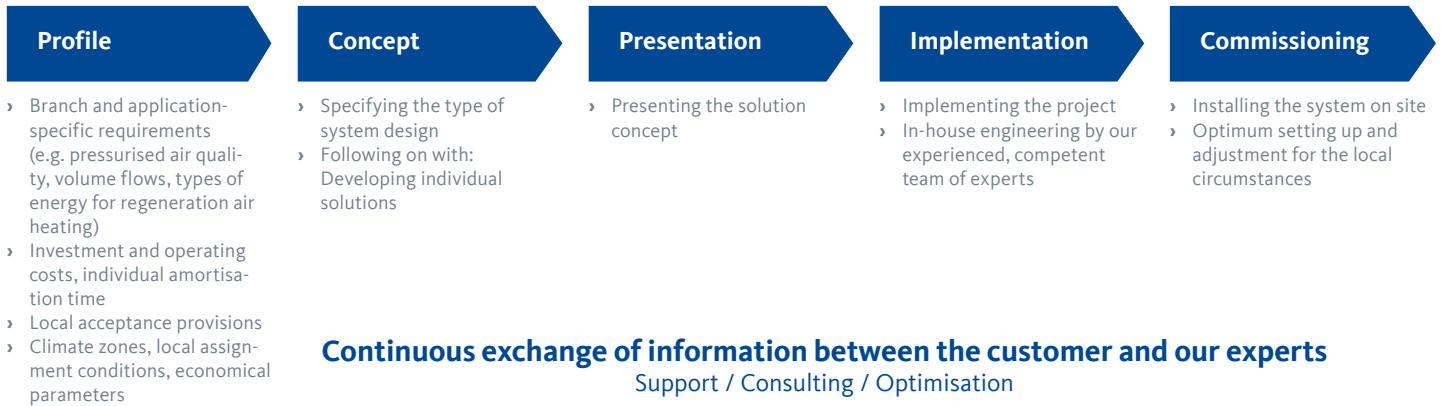

## Function Process for EVERDRY® FRP

### Adsorption stage

The moist compressed air flow enters the system through the valve **K1** and into the adsorption vessel **B1**. The flow distributor ensures an even distribution of the moist compressed air. The moisture will be absorbed by the desiccant during the through flow. The dried pressurised air is then routed via the

outlet valve **R1** and the system outlet to the consumer positions. The absorption process ends based on either the time or dew point (option). Adsorption takes place from the bottom to the top.

### Desorption stage

Whilst the compressed air is being dried in the adsorption vessel **B1**, the adsorption vessel **B2** that has just been saturated with moisture is regenerated. Before the start of regeneration, the pressure in the adsorption vessel **B2** is gently relieved to atmospheric pressure. Desorption takes place with aspirated ambient air. The regeneration fan conveys the ambient air to the subsequent heater. This is where the fan-blown air is heated up to the necessary desorption temperature. The regeneration fan creates an increase in temperature that has a positive effect on the heater's performance. The heated air flow from the fan passes through the valve **R4** to the desorbing adsorption vessel **B2**. The moisture absorbed by the

desiccant evaporates and is routed by the air flow from the fan through the valve **K4** into the atmosphere. Energy-optimised desorption takes place by a counter-flow process. This means that the moisture from the adsorption vessel reaches the atmosphere by the shortest path. The heated fan-blown air cools down when it flows through the adsorption vessel **B2** since the water evaporates. The outlet temperature of the desorption air is therefore not much higher than the evaporation temperature (approx. 40 – 60°C). The moisture level in the desiccant bed reduces with the desorption process. Decreasing moisture levels result in an increase of the outlet temperature of the desorption air. The desorption stage ends when the necessary process temperature is reached. Desorption takes place in the opposite direction to adsorption from the top to the bottom.

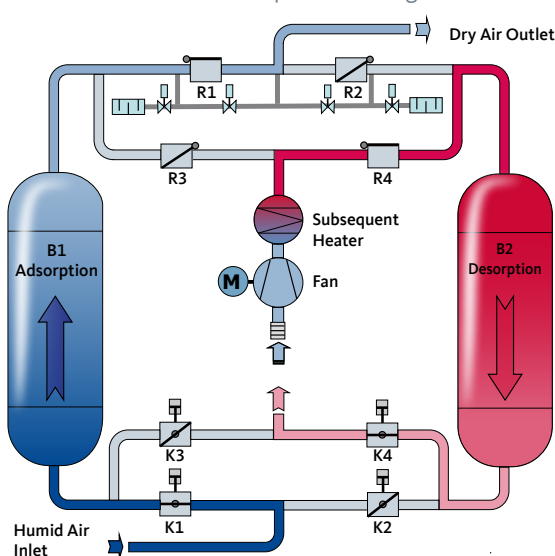

# EVERDRY® FRP: FRP 0600 – FRP 3400

- › Designed for fully automated and continuous operation
- › Desorption in a counter-flow to the adsorption direction by means of heated fan-blown air
- › Cooling by means of a relieved partial flow from the flow of dried compressed air
- › Designed for indoor installation
- › Flow-optimised individual valves to minimise the pressure loss

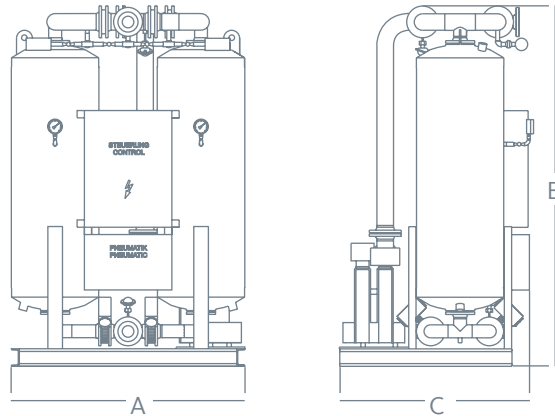

**PURGE**

EVERDRY®	FRP 0600	FRP 0750	FRP 0900	FRP 1100	FRP 1400	FRP 1700
Volume flow rate (m³/h)	580	720	880	1100	1400	1700
Connection PN 16 DIN 2633	DN 50	DN 50	DN 50	DN 80	DN 80	DN 80
Connected load (kW)	10.1	10.1	14.2	14.2	18	25
<b>Dimensions</b>						
A (mm)	1510	1550	1600	1650	1700	1750
B (mm)	2315	2325	2390	2420	2460	2500
C (mm)	1165	1165	1185	1210	1325	1470
Weight (kg)	1100	1200	1300	1550	1800	2100

EVERDRY®	FRP 2000	FRP 2300	FRP 2600	FRP 2900	FRP 3400
Volume flow rate (m³/h)	2000	2300	2600	2900	3400
Connection PN 16 DIN 2633	DN 100	DN 100	DN 100	DN 100	DN 100
Connected load (kW)	28	31	38.5	41.5	48
<b>Dimensions</b>					
A (mm)	1800	1850	1940	1990	2200
B (mm)	2550	2595	2645	2665	2775
C (mm)	1525	1555	1780	1810	1990
Weight (kg)	2400	2600	2900	3100	3600

Operating conditions*	
Medium	Compressed air
Operating pressure	7 bar [g]
Inlet temperature	35 °C
Inlet humidity	saturated
Pressure dew point	-40 °C
Cooling air consumption	on average approx. 2 % relative to the nominal volume flow rate

Limits of use*	
Operating pressure	4...10 bar [g]
Inlet temperature	5...43 °C
Ambient temperature	5...40 °C
Max. fan aspiration	35 °C / 85 % r. F. 40/ 70 °C

Electrical connection*	
Power supply	3 Ph.   400 V   50 Hz
Protection class	IP 54, according to IEC 529 (no explosion protection)
Version	according to VDE / IEC
Permissible voltage deviation	+/- 10 %

\* Different conditions on request

Reference conditions according to DIN / ISO 7183	
Medium	Compressed air
Volume flow rate in m³/h relative to	20 °C (1 bar [g])
Operating pressure	7 bar [g]
Compressed air inlet temperature	35 °C
Inlet humidity	saturated

# EVERDRY® FRP: FRP 4200 – FRP 20000

**PURGE**

- › Designed for fully automated and continuous operation
- › Desorption in a counter-flow to the adsorption direction by means of heated fan-blown air
- › Cooling by means of a relieved partial flow from the flow of dried compressed air
- › Designed for indoor installation
- › Flow-optimised individual valves to minimise the pressure loss

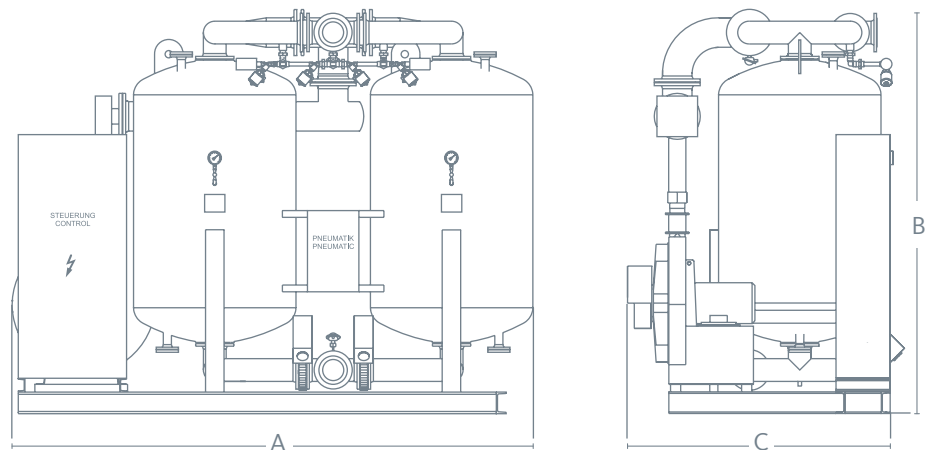

EVERDRY®	FRP 4200	FRP 5000	FRP 6000	FRP 7000	FRP 8200	FRP 9400
Volume flow rate (m³/h)	4200	5000	6000	7000	8200	9350
Connection PN 16 DIN 2633	DN 150	DN 150	DN 150	DN 150	DN 150	DN 200
Connected load (kW)	52.5	69.5	78.5	92	105.5	123
<b>Dimensions</b>						
A (mm)	3355	3500	3755	3915	4335	4295
B (mm)	2860	2920	2985	3045	3130	3215
C (mm)	1935	1935	2010	2135	2265	2565
Weight (kg)	4700	5400	6300	7100	8500	9700

EVERDRY®	FRP 10600	FRP 12000	FRP 13500	FRP 15000	FRP 17000	FRP 20000
Volume flow rate (m³/h)	10600	12000	13500	15000	17000	20000
Connection PN 16 DIN 2633	DN 200	DN 200	DN 200	DN 200	DN 250	DN 250
Connected load (kW)	141	159	177	198.5	220	247
<b>Dimensions</b>						
A (mm)	5000	5400	5600	5900	5600	6600
B (mm)	3400	3400	3500	3500	3650	3700
C (mm)	2700	2800	3000	3100	3500	3800
Weight (kg)	11800	13000	14800	16600	18800	21500

Operating conditions*	
Medium	Compressed air
Operating pressure	7 bar [g]
Inlet temperature	35 °C
Inlet humidity	saturated
Pressure dew point	-40 °C
Cooling air consumption	on average approx. 2 % relative to the nominal volume flow rate

Limits of use*	
Operating pressure	4...10 bar [g]
Inlet temperature	5...43 °C
Ambient temperature	5...40 °C
Max. fan aspiration	35 °C / 85 % r. F. 40/ 70 °C

Electrical connection*	
Power supply	3 Ph.   400 V   50 Hz
Protection class	IP 54, according to IEC 529 (no explosion protection)
Version	according to VDE / IEC
Permissible voltage deviation	+/- 10 %

\* Different conditions on request

Reference conditions according to DIN / ISO 7183	
Medium	Compressed air
Volume flow rate in m³/h relative to	20 °C (1 bar [g])
Operating pressure	7 bar [g]
Compressed air inlet temperature	35 °C
Inlet humidity	saturated

### Cooling stage

To prevent temperature and dew point peaks after the switch over, the heat stored in the desiccant after the desorption stage will be routed off by the relieved dry air partial flow. Cooling takes place in the opposite direction to adsorption from the top to the bottom. Using dried compressed air for the cooling stage prevents any pre-loading of the desiccant.

The use of dried air for cooling leads to an after-desorption in the desiccant and improves the quality of the regeneration.

The cooling stage ends when the necessary process temperature is reached. At the end of the cooling stage, the regeneration valve **K4** closes. This is followed by a gradual build up of pressure in the regenerated adsorption vessel **B2**. The integrated pressure transmitters monitor the correct build up of pressure. The next stage (standby) only begins when both containers have reached the same operating pressure. Cooling takes place in the opposite direction to adsorption from the top to the bottom.

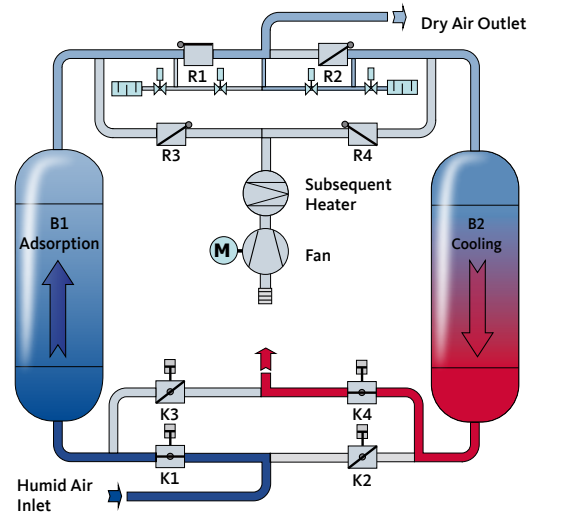

### Standby stage

In the standby stage, the freshly regenerated container with the closed inlet valve (in this case **K2**) is under operating pressure. During this stage, the standby container is kept pressurised via the open pressure build-up valve. If the adsorption stage is monitored via a dew point dependent control system (option) and is then completed, then the duration of the standby stage is dependent on the loading status of the adsorption vessel (in this case **B1**). The switch over process will be only be initiated when the desiccant break-down capacity has been reached (increase in the pressure condensation point). If the system is operated in the “time-dependent switch over” mode, then the initiation of the switching over process will be executed when the set cycle time has expired.

### Parallel Stage

Before the switching over process is executed for the adsorption vessel (in this case from **B1** to **B2**), this will be switched into parallel function by opening the inlet valve (in this case **K2**). The pressurised air flows over both adsorption containers for approx. 5 – 15 minutes (can be set individually).

### Switching Over Procedure

At the end of parallel stage, the system switches over to the regenerated adsorption vessel (in this case **B2**) in the following steps:

- › The inlet valve (in this case **K1**) on the saturated adsorption vessel (in this case **B1**) is closed
- › The pressure build-up valve is closed
- › Open the pressure relief valve for the adsorption vessel to be regenerated (in this case **B1**)
- › The regeneration valve (in this case **K5**) is opened
- › Switch on the fan and heater

The container saturated with moisture **B1** is now located in the desorption stage while the adsorption vessel **B2** assumes the role for drying the pressurised air.

# The Heat Regenerating Adsorption Dryer: At home throughout the world.

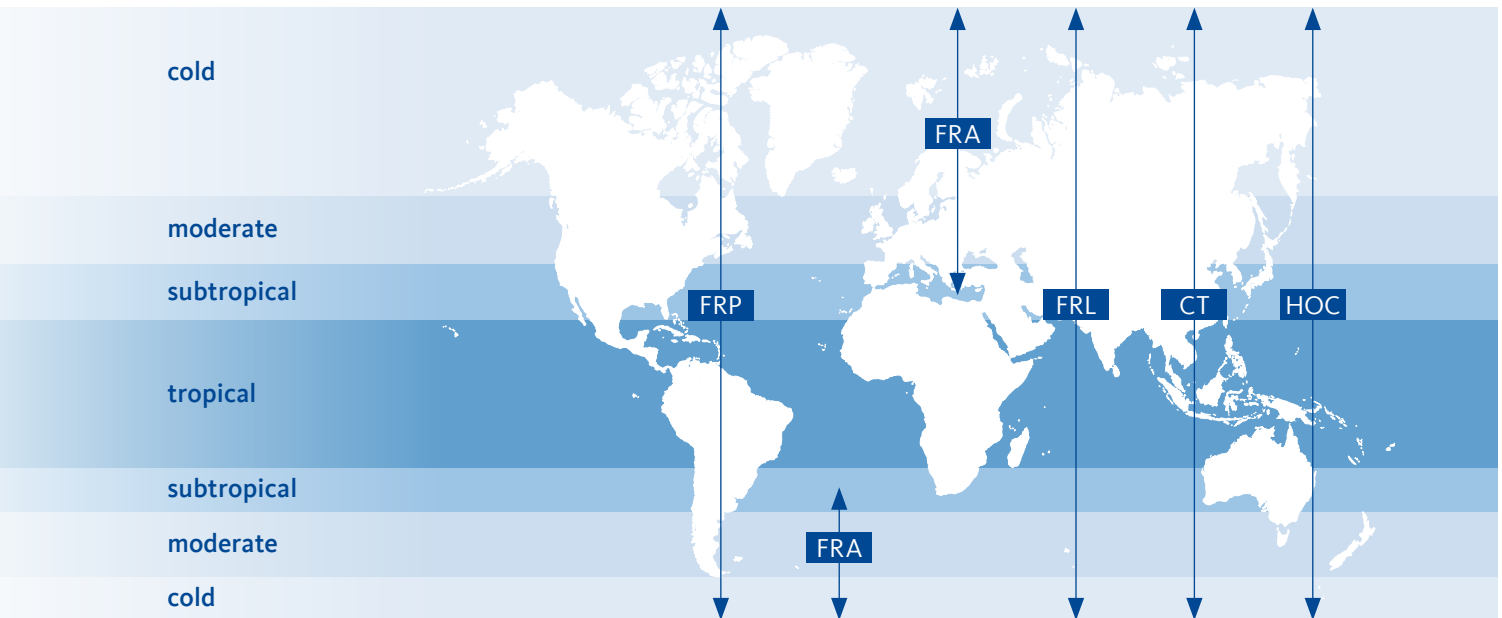

## Do **you** have questions about the best way of processing your compressed air?

We have the answers! We offer efficient solutions for any type of processing chain. Please contact us with your queries. We would be delighted to tell you more about our condensate

treatment, filtration, drying, measuring and process technology, and our comprehensive services.

Visit us at



**BEKO TECHNOLOGIES GMBH**  
Im Taubental 7 | D-41468 Neuss

Telephone +49 2131 988 - 1000  
info@beko-technologies.com  
www.beko-technologies.com



Subject to technical changes without prior notice. Errors and omissions excepted.